

ID SERIES DATASHEET Feb 10 , 2004

ID-2 / ID-12 / ID-20

The ID2, ID12 and ID20 are similar to the ID0, ID10 and ID15 MK(ii) series devices, but they have extra pins which allow Magnetic Emulation output to be included in the functionality. The ID-12 and ID-20 come with internal antennas, and have read ranges of 12+ cm and 16+ cm, respectively. With an external antenna, the ID-2 can deliver read ranges of up to 25 cm. All three readers support ASCII, Wiegand26 and Magnetic ABA Track2 data formats.



ID2 / ID12 / ID20 PIN-OUT

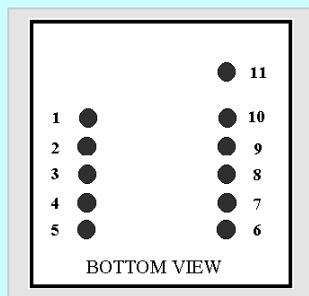

1. GND
2. RES (Reset Bar)
3. ANT (Antenna)
4. ANT (Antenna)
5. CP
6. Future
7. +/- (Format Selector)
8. D1 (Data Pin 1)
9. D0 (Data Pin 0)
10. LED (LED / Beeper)
11. +5V

Operational and Physical Characteristics

Parameters	ID-2	ID-12	ID-20
Read Range	N/A (no internal antenna)	12+ cm	16+ cm
Dimensions	21 mm x 19 mm x 6 mm	26 mm x 25 mm x 7 mm	40 mm x 40 mm x 9 mm
Frequency	125 kHz	125 kHz	125 kHz
Card Format	EM 4001 or compatible	EM 4001 or compatible	EM 4001 or compatible
Encoding	Manchester 64-bit, modulus 64	Manchester 64-bit, modulus 64	Manchester 64-bit, modulus 64
Power Requirement	5 VDC @ 13mA nominal	5 VDC @ 30mA nominal	5 VDC @ 65mA nominal
I/O Output Current	+/-200mA PK	-	-
Voltage Supply Range	+4.6V through +5.4V	+4.6V through +5.4V	+4.6V through +5.4V

Pin Description & Output Data Formats

Pin No.	Description	ASCII	Magnet Emulation	Wiegand26
Pin 1	Zero Volts and Tuning Capacitor Ground	GND 0V	GND 0V	GND 0V
Pin 2	Strap to +5V	Reset Bar	Reset Bar	Reset Bar
Pin 3	To External Antenna and Tuning Capacitor	Antenna	Antenna	Antenna
Pin 4	To External Antenna	Antenna	Antenna	Antenna
Pin 5	Card Present	No function	Card Present	No function
Pin 6	Future	Future	Future	Future
Pin 7	Format Selector (+/-)	Strap to GND	Strap to Pin 10	Strap to +5V
Pin 8	Data 1	CMOS	Clock	One Output
Pin 9	Data 0	TTL Data (inverted)	Data	Zero Output
Pin 10	3.1 kHz Logic	Beeper / LED	Beeper / LED	Beeper / LED
Pin 11	DC Voltage Supply	+5V	+5V	+5V

ID Innovations

Advanced Digital Reader Technology

---Better by Design

Circuit Diagram for the ID0

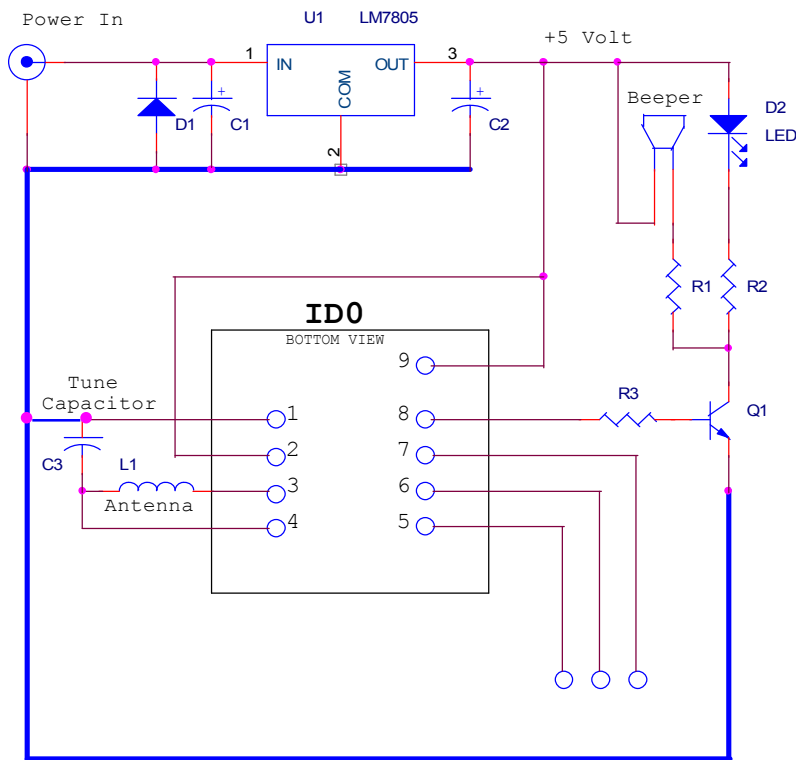

COMPONENT LIST

R1 = 100R
 R2 = 1K
 R3 = 1K
 C1 = 100uF 16V
 C2 = 100uF 10V
 C3 = 1nF COG 100V *
 Beeper = 2.7-3.5KHz 100R
 D1 = 1N4001
 D2 = GREEN LED
 U1 = LM7805
 Q1 = UTC8050 (NPN)
 L1 = 640uH

ID0 = ID Innovations ID0

* Please Note the ID0 has an internal tuning capacitor of 1.5nF and this makes the total tuning capacity = 2.5nF

The 3.1Khz Beeper Logic is centered for most Beepers in range 2.7-3.5Khz

Circuit Diagram for the ID2

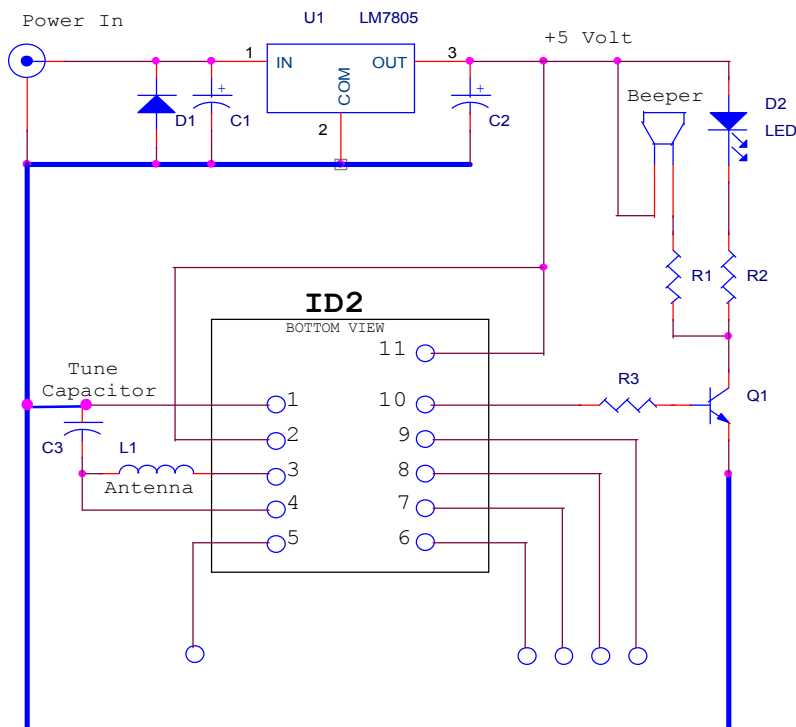

COMPONENT LIST

R1 = 100R
 R2 = 1K
 R3 = 1K
 C1 = 100uF 16V
 C2 = 100uF 10V
 C3 = 1nF COG 100V *
 Beeper = 2.7-3.5KHz 100R
 D1 = 1N4001
 D2 = GREEN LED
 U1 = LM7805
 Q1 = UTC8050 (NPN)
 L1 = 640uH

ID2 = ID Innovations ID2

* Please Note the ID2 has an internal tuning capacitor of 1.5nF and this makes the total tuning capacity = 2.5nF

The 3.1Khz Beeper Logic is centered for most Beepers in range 2.7-3.5Khz

ID Innovations

Advanced Digital Reader Technology

----Better by Design

Circuit Diagram for the ID-12

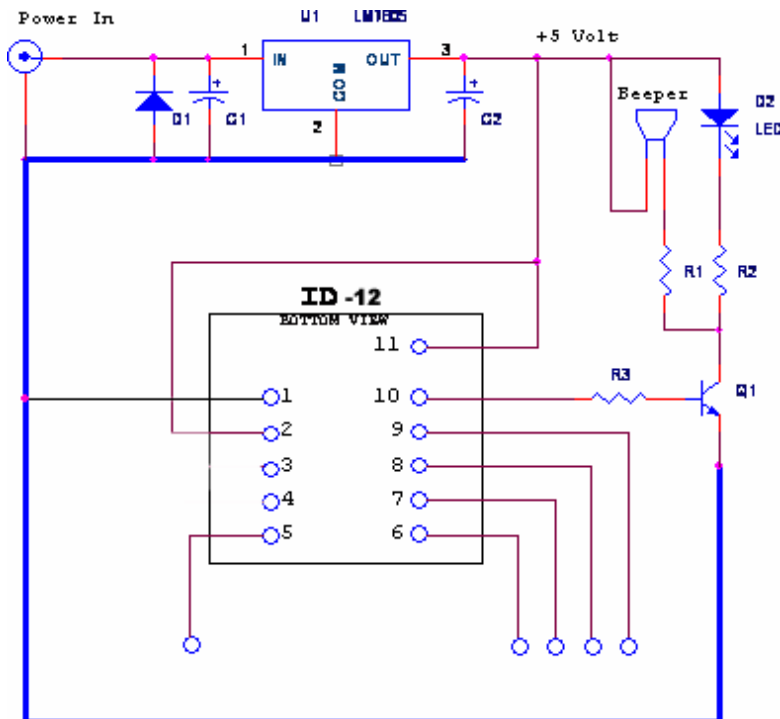

COMPONENT LIST

- R1 = 100R
- R2 = 1K
- R3 = 1K
- C1 = 100uF 16V
- C2 = 100uF 10V
- Beeper = 2.7-3.5KHz 100R
- D1 = 1N4001
- D2 = GREEN LED
- U1 = LM7805
- Q1 = UTC8050 (NPN)
- ID2 = ID Innovations ID2

* Please Note the ID2 has an internal tuning capacitor of 1.5nF and this makes the total tuning capacity = 2.5nF

The 3.1Khz Beeper Logic is centered for most Beepers in range 2.7-3.5Khz

ID Innovations

Advanced Digital Reader Technology

---Better by Design

ID-2RW, ID-12RW Brief Data

The ID2-RW, ID12-RW and ID15-RW are a new series of Read/Write modules for the Temec Q5 tag. It has full functionality including password. They contain built-in algorithms to assist customers programming the popular Sokymat Unique type tag. Password protection is allowed. Control is via a host computer using a simple terminal program such as hyper terminal or Qmodem.

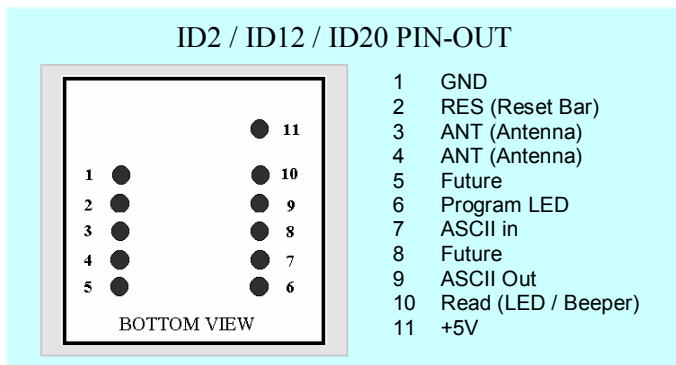

Operational and Physical Characteristics

Parameters	ID-2RW	ID-12RW	ID-20RW
Read Range	N/A (no internal antenna)	12+ cm (Unique Format)	15+ cm (Unique Format)
Dimensions	21 mm x 19 mm x 6 mm	26 mm x 25 mm x 7 mm	40 mm x 40 mm x 9 mm
Frequency	125 kHz	125 kHz	125 kHz
Card Format	Temec Q5555	Temec Q5555	Temec Q5555
Read Encoding	Manchester modulus 64	Manchester modulus 64	Manchester modulus 64
Power Requirement	5 VDC @ 13mA nominal	5 VDC @ 30mA nominal	5 VDC @ 50mA nominal
I/O Output Current	+/-200mA PK	-	-
Voltage Supply Range	+4.6V through +5.4V	+4.6V through +5.4V	+4.6V through +5.4V
Coil Detail	L = 0.6mH - 1.5mH, Q = 15-30	-	-

Description

A host computer is required to send the commands to the module. A simple terminal program such as Qmodem or Hyper-terminal can be used to send commands to the module. The blocks are individually programmable. If you have ever found that the Q5 can be a bit 'Twitchy' to program this programmer module is your solution. The command interface is simple to use and easily understood. The programmer also has two types of internal reader. One of these is provided to read Sokymat 'Unique' type tag configuration.

ID Innovations Low Cost Short-Range Proximity Readers

ID-0 / ID-10 / ID-15 MK(ii) Series

Maintenance only. Consider using the ID-2, ID-12 and the ID-20 that have improved performance.

The ID Series short-range readers come in three different sizes and read ranges. Both the ID-10 and ID-15 come with internal antennas, and have read ranges of 12+ cm and 16+ cm, respectively. With an external antenna, the ID-0 Mk(ii) can deliver read ranges of up to 25 cm. All three readers support ASCII and Wiegand26 data formats.

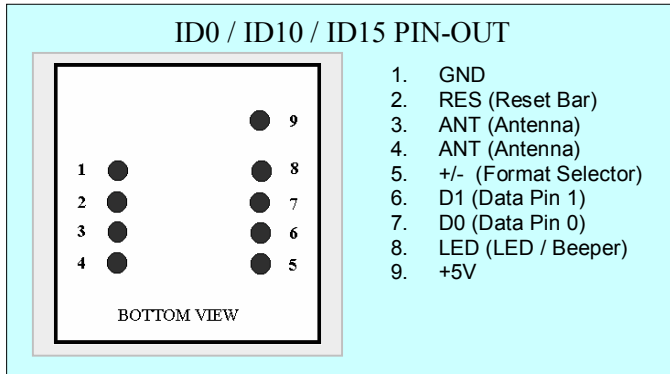

Operational and Physical Characteristics

Parameters	ID-0	ID-10	ID-15
Read Range	N/A (no internal antenna)	12+ cm	15+ cm
Dimensions	21 mm x 19 mm x 6 mm	26 mm x 25 mm x 7 mm	40 mm x 40 mm x 9 mm
Frequency	125 kHz	125 kHz	125 kHz
Card Format	EM 4001 or compatible	EM 4001 or compatible	EM 4001 or compatible
Encoding	Manchester 64-bit, modulus 64	Manchester 64-bit, modulus 64	Manchester 64-bit, modulus 64
Power Requirement	5 VDC @ 13mA nominal	5 VDC @ 30mA nominal	5 VDC @ 50mA nominal
I/O Output Current	+/-200mA PK	-	-
Voltage Supply Range	+4.6V through +5.4V	+4.6V through +5.4V	+4.6V through +5.4V

Pin Description & Output Data Formats

Pin No.	Description	ASCII	Wiegand26
Pin 1	Zero Volts and Tuning Capacitor Ground	GND 0V	GND 0V
Pin 2	Strap to +5V	Reset Bar	Reset Bar
Pin 3	To External Antenna and Tuning Capacitor	Antenna	Antenna
Pin 4	To External Antenna	Antenna	Antenna
Pin 5	Format Selector (+/-)	Strap to GND	Strap to +5V
Pin 6	Data 1	CMOS	One Output
Pin 7	Data 0	TTL Data (inverted)	Zero Output
Pin 8	3.1 kHz Logic	Beeper / LED	Beeper / LED
Pin 9	DC Voltage Supply	+5V	+5V

ID Innovations

Advanced Digital Reader Technology

---Better by Design

Customer enquiry: help@id-innovations.com

DATA FORMATS

Output Data Structure – ASCII

STX (02h)	DATA (10 ASCII)	CHECK SUM (2 ASCII)	CR	LF	ETX (03h)
-----------	-----------------	---------------------	----	----	-----------

[The 1byte (2 ASCII characters) Check sum is the “Exclusive OR” of the 5 hex bytes (10 ASCII) Data characters.]

Output Data Structure – Wiegand26

1	2	3	4	5	6	7	8	9	10	11	12	13	14	15	16	17	18	19	20	21	22	23	24	25	26
P	E	E	E	E	E	E	E	E	E	E	E	E	O	O	O	O	O	O	O	O	O	O	O	O	P
Even parity (E)													Odd parity (O)												

P = Parity start bit and stop bit

Output Data Magnetic ABA Track2

10 Leading Zeros	SS	Data	ES	LCR	10 Ending Zeros
------------------	----	------	----	-----	-----------------

[SS is the Start Character of 11010, ES is the end character of 11111, LRC is the Longitudinal Redundancy Check.]

Dimensions (Top View) (mm)

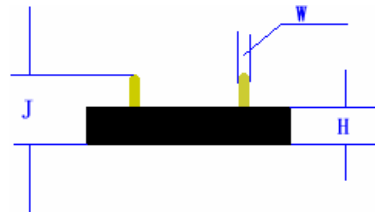
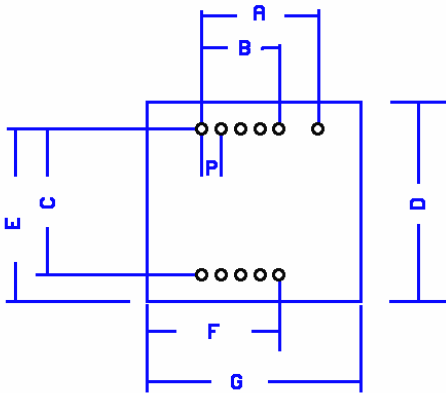

	ID-0/ID-2			ID-10/ID-12			ID-15/ID-20		
	Nom.	Min.	Max.	Nom.	Min.	Max.	Nom.	Min.	Max.
A	12.0	11.6	12.4	12.0	11.6	12.4	12.0	11.6	12.4
B	8.0	7.6	8.4	8.0	7.6	8.4	8.0	7.6	8.4
C	15.0	14.6	15.4	15.0	14.6	15.4	15.0	14.6	15.4
D	20.5	20.0	21.5	25.3	24.9	25.9	40.3	40.0	41.0
E	18.5	18.0	19.2	20.3	19.8	20.9	27.8	27.5	28.5
F	14.0	13.0	14.8	16.3	15.8	16.9	22.2	21.9	23.1
G	22.0	21.6	22.4	26.4	26.1	27.1	38.5	38.2	39.2
P	2.0	1.8	2.2	2.0	1.8	2.2	2.0	1.8	2.2
H	5.92	5.85	6.6	6.0	5.8	6.6	6.8	6.7	7.0
J	9.85	9.0	10.5	9.9	9.40	10.5	9.85	9.4	10.6
W	0.66	0.62	0.67	0.66	0.62	0.67	0.66	0.62	0.67

Note – measurements do not include any burring of edges.

NOTICE - Innovated Devices reserve the right to change these specifications without prior notice.

ID Innovations

Advanced Digital Reader Technology

----Better by Design